

# MITSUBISHI

## 三菱工業用ミシン部品カタログ

## Industrial Sewing Machine Parts Catalog

### Model DY-350<sup>-12</sup>/<sub>-22</sub>

目次	INDEX	Page
1. 機 構 図	Total assembly .....	1
2. 本 体 間 係	Arm bed & its accessories .....	2
3. 縫 機 構	Sewing mechanism .....	4
4. 縫 目 調 節 、 下 送 り 機 構	Stitch length regulator & Lower feed mechanism .....	6
5. 上 部 送 り 機 構	Upper feed mechanism .....	8
6. 押 工 機 構	Presser foot mechanism .....	10
7. 給 油 間 係	Oil lubrication mechanism .....	10
8. 付 属 品 間 係	Accessories .....	12

① 全体構成  
CONSTRUCTION

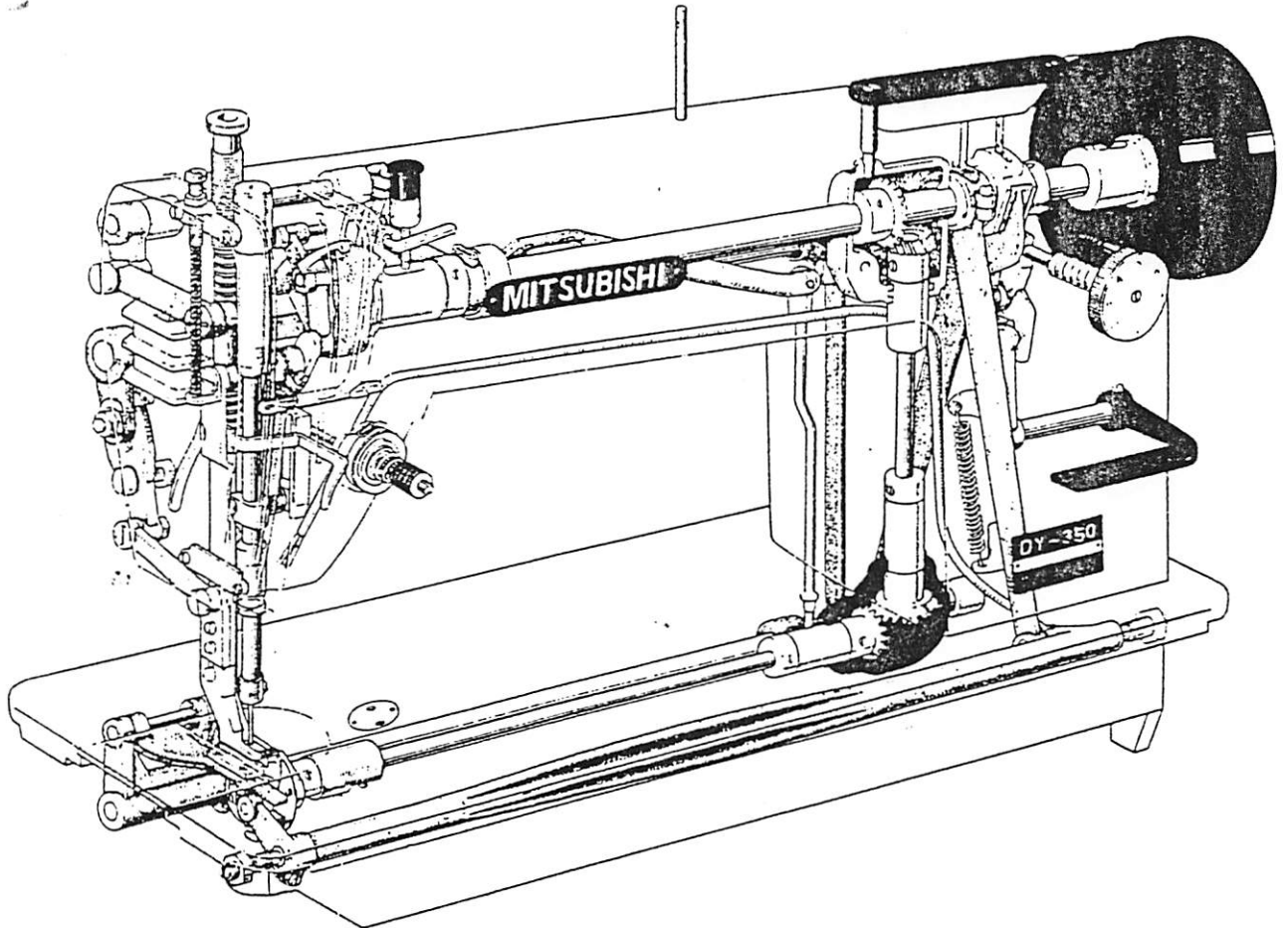

# ミシン用部品コード採番基準 MITSUBISHI SPARE PARTS No. Designation system

注：※欄には英文字(A,B,……X,Y,Z)が入る。  
Remarks: Alphabet (A,B,……X,Y,Z) should be taken at ※ mark.

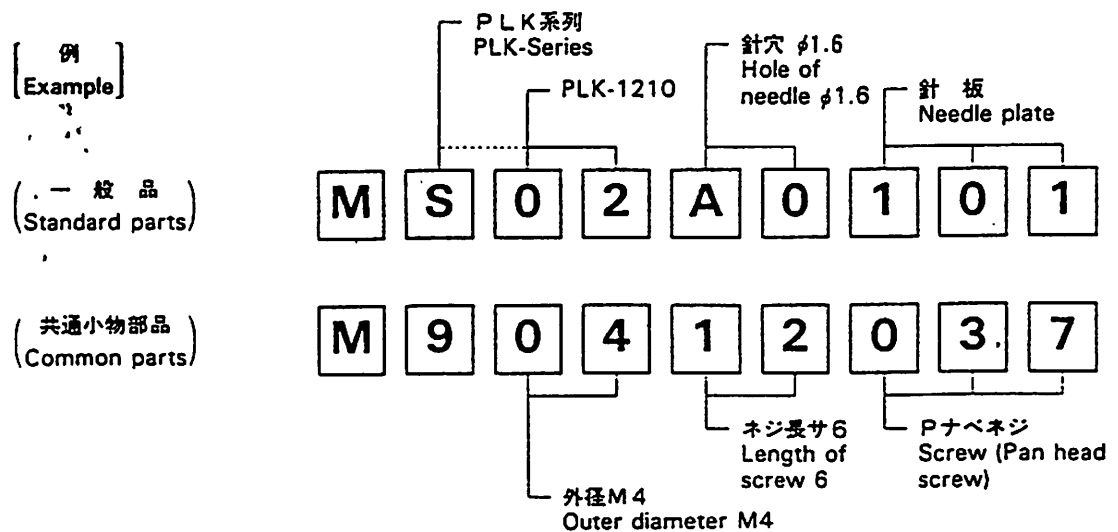
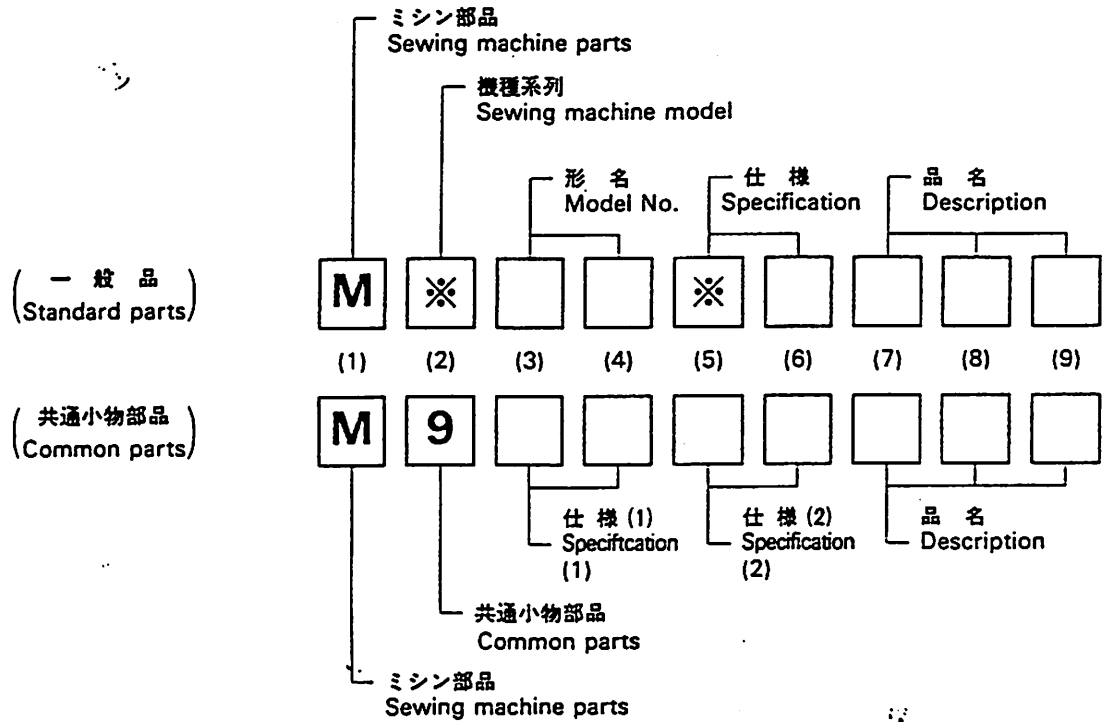

注：一般品についての機種形名は、その部品が最初に使用された機種形名を示します。従って長期に亘る場合は、機種の変更が行われるため、当初の機種以外の機種で使用されている場合があります。

Sewing machine Models, of Standard Parts are indicated model of these parts are registered firstly. Parts are used for not only the indicated model, but also another models, in reason of New development, Improvement after.

② 本体関係  
**ARM BED & ITS ACCESSORIES**

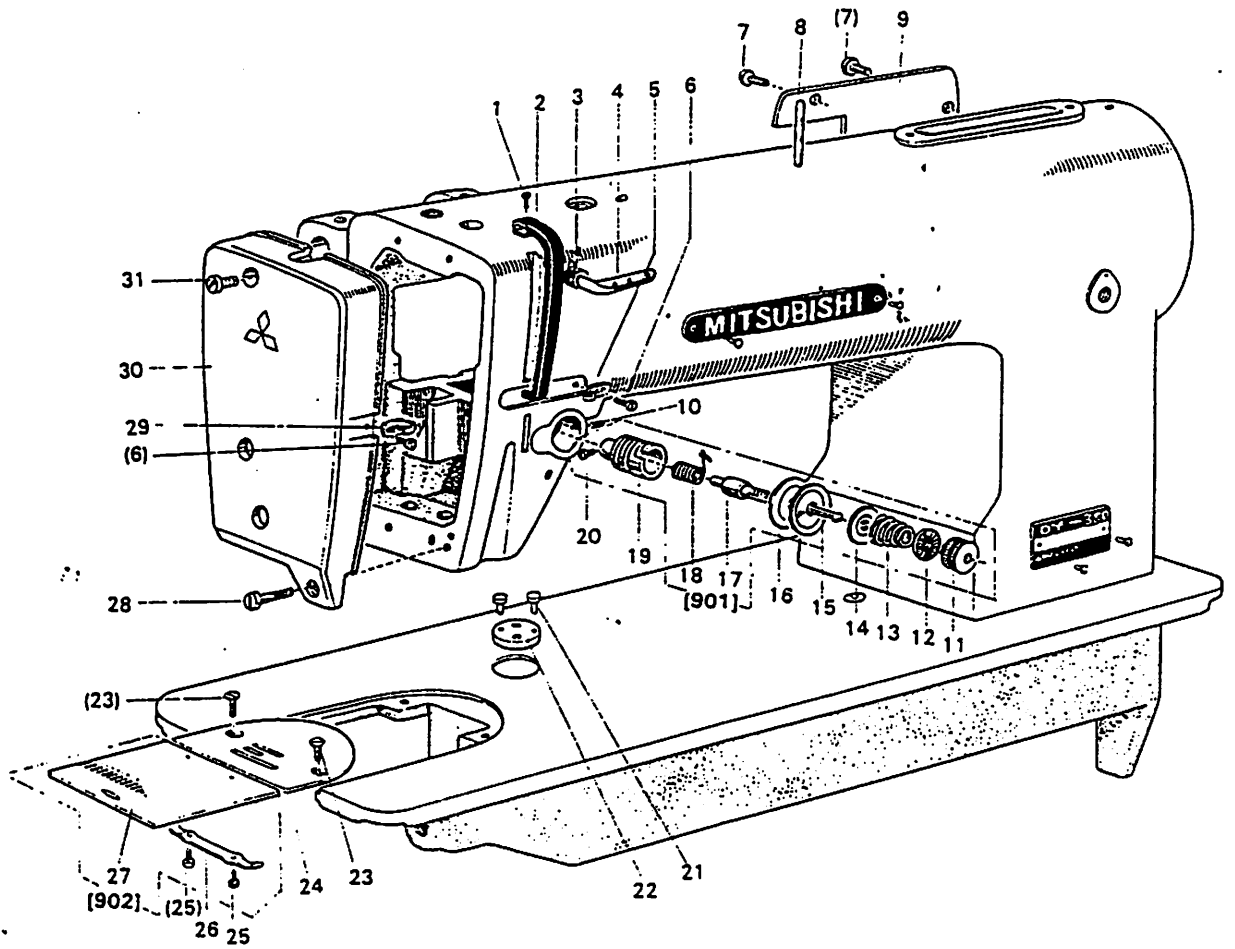

# ARM BED & ITS ACCESSORIES

Fig. No.	部品コード Parts No.	部 品 名	Description	使用個数 Amt. Req. DY-350 -12 -22	資材コード Ref. No.
1	M9 1107 002	平 ネ ジ	$\frac{1}{64}(40) \times 5.5$ .....Screw $\frac{1}{64}(40) \times 5.5$ .....	1 1	W500092H01
2	MF 02A0 584	天 秤 カ バ ー	.....Thread take-up cover.....	1	A131C223H01
	MF 00A0 584	天 秤 カ バ ー	.....Thread take-up cover.....	1	A131C220H01
3	M9 1108 001	頭 ナシ止メネジ	$\frac{1}{64}(40) \times 5.5$ .....Set screw $\frac{1}{64}(40) \times 5.5$ .....	1 1	B503846H01
4	MF 10A0 180	三 ツ 目 糸 掛	.....Three hole thread guide.....	1 1	B409034H01
5	MF 80A0 181	糸 掛	(アーム).....Thread guide for arm.....	1	W483484H01
	MG 43A0 181	糸 掛	(アーム).....Thread guide for arm.....	—	W487126H01
6	M9 0909 003	丸 平 ネ ジ	$\frac{1}{64}(40) \times 6$ .....Screw $\frac{1}{64}(40) \times 6$ .....	2 2	W501901H01
7	M9 1109 003	平 ネ ジ	$\frac{1}{64}(40) \times 7$ .....Screw $\frac{1}{64}(40) \times 7$ .....	4 4	W500511H01
8	MF 10A0 186	糸 立 棒	.....Spool pin.....	1 1	W461744H01
9	MG 42A1 880	横 蓋	.....Arm side cover.....	1 1	A142D521H01
10	M9 1522 001	頭 ナシ止メネジ	$\frac{1}{64}(28) \times 6$ .....Set screw $\frac{1}{64}(28) \times 6$ .....	1 1	A142D245H01
11	M9 1608 046	調 子 ナ ッ ト	$\frac{1}{4}(40)$ .....Thread tension regulating thumb nut $\frac{1}{4}(40)$ .....	1 1	W476469H01
12	MT 60A0 802	回 リ 止 メ	.....Thumb nut revolution stopper.....	1 1	W476470H01
13	MF 43C0 245	糸 調 子 バ ネ	.....Thread tension spring.....	1 1	W478173H01
14	MM 11A0 556	調 子 血 押 エ	.....Thread tension releasing disc.....	1 1	W477611H01
15	M9 0204 060	ピ ン	$\phi 2 \times 28.4$ .....Thread tension releasing pin $\phi 2 \times 28.4$ .....	1 1	B509216H01
16	MF 10A0 555	調 子 血 押	.....Thread tension disc.....	2 2	W444059H01
17	MF 10A0 553	調 子 血 押	.....Thread tension stud.....	1 1	B419178H01
18	MF 12B0 187	糸 取 リ バ ネ	.....Thread take-up spring.....	1 1	W486372H02
19	MF 10A0 709	バネ止メブッシュ	.....Thread tension regulator bushing.....	1 1	W453140H01
20	M9 0901 002	平 ネ ジ	$\frac{1}{64}(40) \times 4$ .....Screw $\frac{1}{64}(40) \times 4$ .....	1 1	W500741H01
901	MF 12E0 210	上 糸 調 節 器	(組).....Thread tension regulator complete.....	1 1	W346065G07
21	M9 1107 002	平 ネ ジ	$\frac{1}{64}(40) \times 5.5$ .....Screw $\frac{1}{64}(40) \times 5.5$ .....	2 2	W500092H01
22	MG 30A0 601	取 付 板	.....Cloth guide plate.....	1 1	W483494H01
23	M9 1106 011	丸 皿 ネ ジ	$\frac{1}{64}(40) \times 8$ .....Screw $\frac{1}{64}(40) \times 8$ .....	2 2	W502948H01
24	MF 26B0 101	針 板	B2.6(7mm) .....Needle plate B2.6 (7 mm).....	1 1	W322721H01
25	M9 0604 002	平 ネ ジ	$\frac{3}{32}(56) \times 2.2$ .....Screw $\frac{3}{32}(56) \times 2.2$ .....	2 2	B509070H01
26	MF 10A0 471	ス へ リ 板 バ ネ	.....Spring for slide plate.....	1 1	B419207H01
27	MG 30A0 470	ス へ リ 板	.....Slide plate.....	1 1	B419208H02
902	MF 80E0 470	ス へ リ 板	(組).....Slide plate complete.....	1 1	W461757G02
28	M9 1106 003	丸 平 ネ ジ	$\frac{1}{64}(40) \times 20$ .....Screw $\frac{1}{64}(40) \times 20$ .....	1 1	W500369H01
29	MF 10A0 181	糸 掛	(面板).....Thread guide for face plate.....	1	W452151H01
	MG 43A1 181	糸 掛	(面板).....Thread guide for face plate.....	—	W487127H01
30	MG 30A1 830	面 板	.....Face plate.....	1 1	W344935H01
31	M9 1075 003	丸 平 ネ ジ	M4×30 .....Screw M4 × 30.....	1 1	S901N854P30

③ 縫機構

SEWING MECHANISM

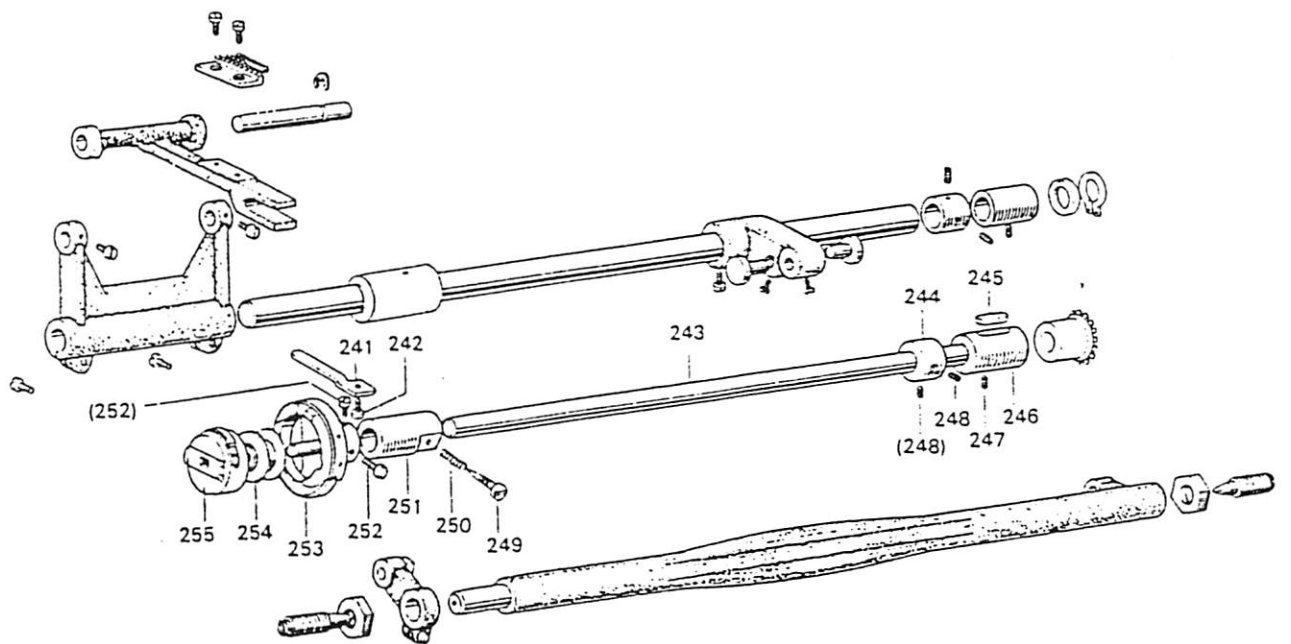
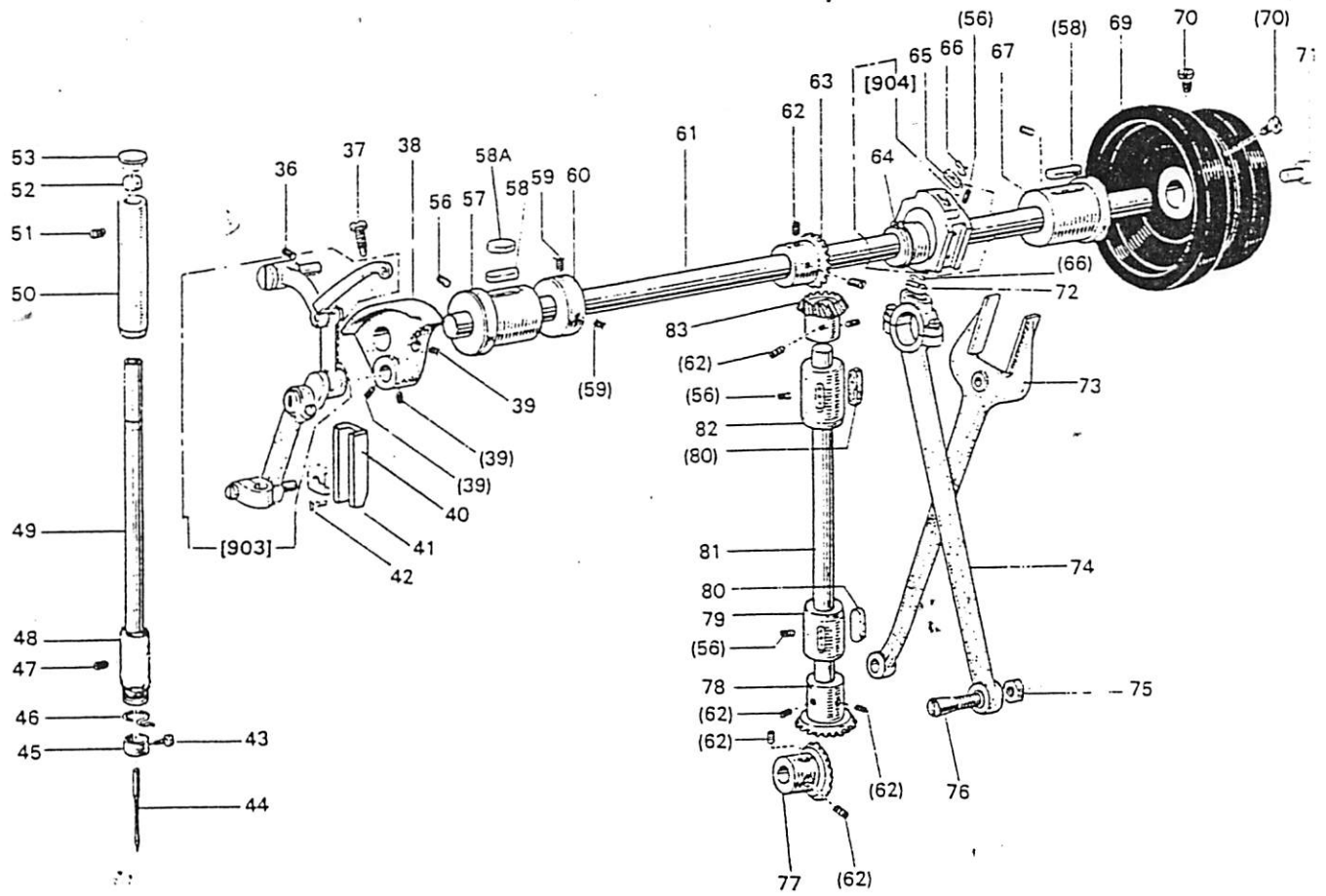
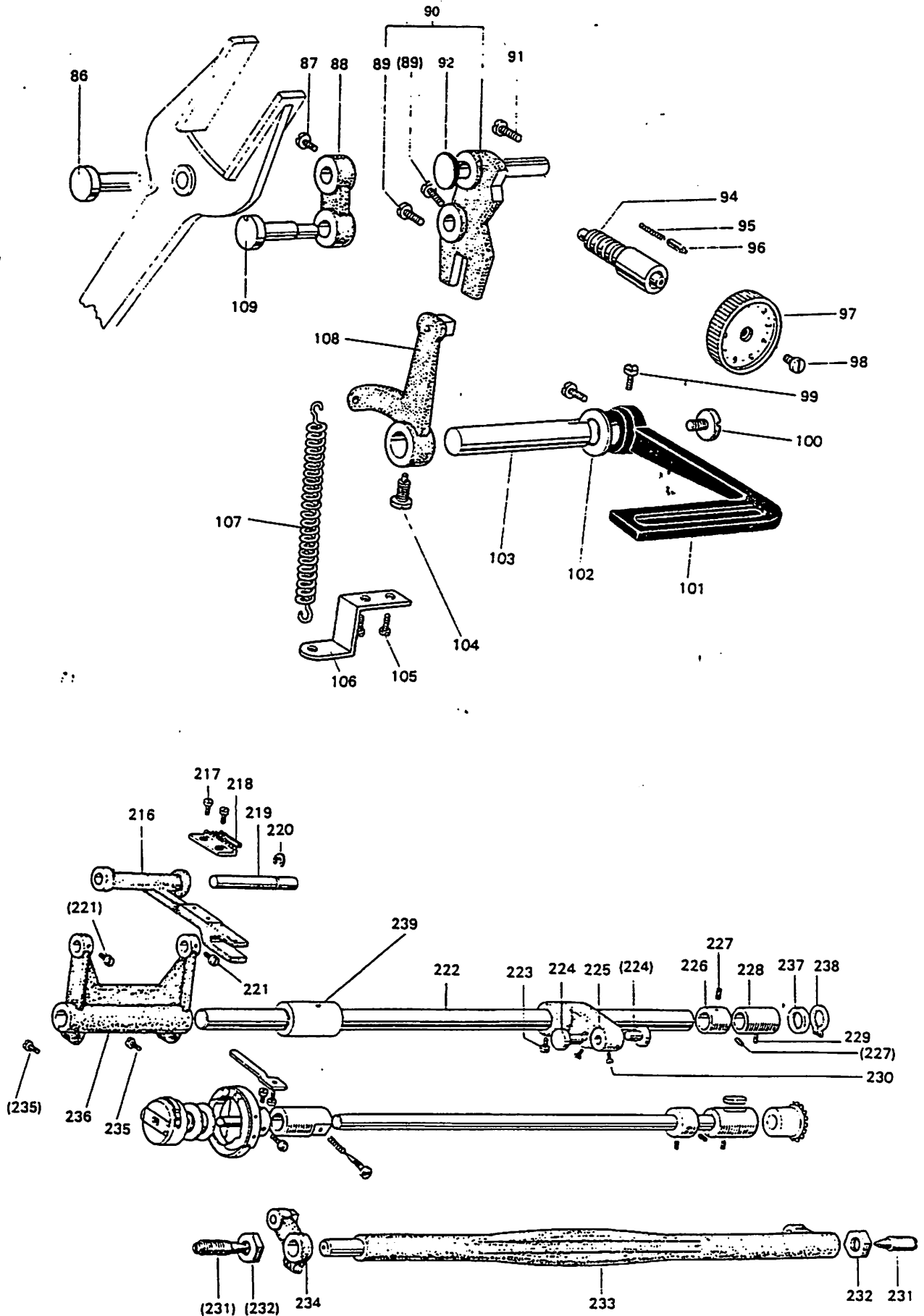

Fig. No.	部品コード Parts No.	部品名	Description	Amt. Req. DY-350 -12 -22	使用個数	資材コード Ref. No.
36	M9 1519 001	頭ナシ止メネジ	1/4(28)×23.5	Set screw 1/4(28)×23.5	1	B509114H01
37	M9 1802 006	棒先止メネジ	1/4(28)×14	Screw 1/4(28)×14	1	B503851H01
38	MF 60A1 383	クランク		Crank	1	W450075H03
39	M9 1606 001	頭ナシ止メネジ	1/4(40)×7	Set screw 1/4(40)×7	3	B504016H01
40	MF 80AO 662	針クガイド		Needle bar connecting link guide	1	W444056H02
41	MF 10AO 325	角駒		Square block	1	W443934H01
42	M9 1110 002	平ネジ	1/4(40)×8	Screw 1/4(40)×8	2	W500294H01
	MF 62E0 580	天祥針ク(組)		Thread take-up lever complete	1	W331012G01
903	MF 67E0 580	天祥針ク(組)		Thread take-up lever complete	1	W331012G02
43	M9 0815 002	平ネジ	1/4(44)×4.5	Screw 1/4(44)×4.5	1	W484210H01
	MF 83AO 128	針	DB×1 #22	Needle DB×1 #22	1	S970002H03
44	MG 37AO 128	針	DP×17 #22	Needle DP×17 #22	1	S970005H07
45	MG 42AO 181	糸掛(針棒)		Thread guide for needle bar	1	W487123H01
46	MG 37A1 181	糸掛(針棒メタル)		Thread guide for needle bar bushing (under)	1	W487001H01
47	M9 1102 001	頭ナシ止メネジ	1/4(40)×2.7	Set screw 1/4(40)×2.7	1	W500489H01
48	MG 30AO 664	針棒メタル(下)		Needle bar bushing (under)	1	W487002H01
49	MG 30AO 660	針棒		Needle bar	1	W483477H01
50	MF 60AO 663	針棒メタル(上)		Needle bar bushing (upper)	1	W461760H01
51	M9 1503 001	頭ナシ止メネジ	1/4(28)×4.5	Set screw 1/4(28)×4.5	1	B508971H01
52	MF 10A2 740	フェルト		Felt for needle bar bushing (upper)	1	W500003H01
53	MF 60AO 742	蓋		Cap for needle bar bushing (upper)	1	W502181H01
56	M9 1508 001	頭ナシ止メネジ	1/4(28)×6	Set screw 1/4(28)×6	3	B509087H01
57	MF 60AO 232	上軸メタル(左)		Arm shaft bushing (left)	1	W464011H01
58	MF 60A2 740	フェルト		Felt for arm shaft bushing	2	W501524H01
59	M9 1602 001	頭ナシ止メネジ	1/4(40)×4	Set screw 1/4(40)×4	2	W500036H01
60	MF 80AO 352	カラ		Collar for arm shaft	1	W482357H01
61	MF 60AO 230	上軸		Arm shaft	1	W326240H01
62	M9 1606 001	頭ナシ止メネジ	1/4(40)×7	Set screw 1/4(40)×7	8	P911000X01
63	MF 40AO 331	傘歯車(上軸)		Bevel gear for arm shaft	1	P611003X02
64	M9 0520 065	C形止メ輪		C-type stop ring	1	S922N010P20
904	MF 70E0 280	送りカム(組)		Feed cam complete	1	W331027G02
65	MF 60A1 740	フェルト		Felt for feed cam	1	W500738H01
66	MF 60AO 700	バネ		Spring for feed cam	2	W500836H01
67	MF 60AO 233	上軸メタル(右)		Arm shaft bushing (right)	1	W451575H01
	MF 85A0682	ハズミ車		Balance wheel	1	A131C217H01
69	MG 43AO 682	ハズミ車		Balance wheel	1	W231701H03
70	M9 1502 002	平ネジ	1/4(28)×12	Screw 1/4(28)×12	2	W500509H01
71	M9 2201 003	丸平ネジ	1/2(28)×10	Screw 1/2(28)×10	1	W461726H01
72	MG 30B0 740	フェルト		Felt for crank rod	1	W464014H01
73	MF 65B0 744	フタ		Feed forked connecting rod	1	W324562H01
74	MF 60AO 384	クランクロッド		Crank rod	1	W321787H01
75	M9 1802 045	ナット	1/2(28)	Nut 1/2(28)	1	B508961H01
76	M9 1803 036	テーパ頭ネジ	1/2(28)×23	Taper screw 1/2(28)×23	1	B508959H01
77	MF 40AO 332	傘歯車(下軸)		Bevel gear for hook shaft	1	P611002X02
78	MF 40AO 334	傘歯車(下軸下)		Bevel gear for vertical shaft (under)	1	P611001X02
79	MF 67B0 522	垂直軸メタル(下)		Vertical shaft bushing (under)	1	W462734H01
80	MF 60AO 740	フェルト		Felt for vertical shaft bushing	2	W500042H01
81	MF 67B0 520	垂直軸		Vertical shaft	1	W444124H01
82	MF 70AO 521	垂直軸メタル(上)		Vertical shaft bushing (upper)	1	W462791H01
83	MF 40AO 333	傘歯車(上軸上)		Bevel gear for vertical shaft (upper)	1	P611000X02
58A	MF 50AO740	フェルト		Felt for arm shaft bushing	1	W501137H01
	MF 10AO 229	内ガマ止メ		Rotating hook positioner	1	W462633H01
241	MF 20AO 229	内ガマ止メ		Rotating hook positioner	1	W468837H01
242	M9 1118 002	平ネジ	1/4(40)×10	Screw 1/4(40)×10	1	B509061H01
243	MG 42A1 450	下軸		Rotating hook shaft	1	A142D519H02
244	MF 10AO 352	カラ		Collar for rotating hook shaft	1	B422844H02
245	MF 60AO 740	フェルト		Felt	1	W500042H01
246	MG 37B0 452	下軸メタル(右)		Rotating hook shaft bushing (right)	1	W462738H01
247	M9 1117 002	丸平ネジ	1/4(40)×13	Screw 1/4(40)×13	1	B503844H01
248	M9 1106 001	頭ナシ止メネジ	1/4(28)×4.5	Set screw 1/4(28)×4.5	2	B509266H01
249	M9 0801 006	棒先平ネジ	M3×0.35×9.5	Screw M3×0.35×9.5	1	W487008H01
250	MG 30AO 700	バネ		Spring	1	W487009H01
251	MG 42A1 451	下軸メタル(左)(組)		Rotating hook shaft bushing (left)	1	A131C341G03
252	M9 1103 002	平ネジ	1/4(40)×5	Screw 1/4(40)×5	2	B509062H01
	MF 42AO 120	カラ	HSL-AN	Rotating hook complete HSL-AN	1	P975009X01
253	MF 25B0 120	カラ	HSM-A	Rotating hook complete HSM-A	1	P975033X01
	MF 10AO 123	ボビン		Bobbin	1	P976019X01
254	MF 25B0 123	ボビン		Bobbin	1	P976021X01
	MF 10E0 125	ボビンケース(組)		Bobbin case complete	1	P976009X01
255	MF 25E1 125	ボビンケース(組)		Bobbin case complete	1	P976020X01

4 縫目調節、下送り機構

STITCH LENGTH REGULATOR & LOWER FEED MECHANISM





4 縫目調節、下送り機構

STITCH LENGTH REGULATOR & LOWER FEED MECHANISM

Fig. No.	部品コード Parts No.	部品名	Description	使用個数 Amt. Req. DY-350 -12 -22	実材コード Ref. No.
86	M9 0720 063	段付軸 (段付ピン)	Set pin	1 1	W481425H02
87	M9 1501 002	平ネジ $\frac{1}{8}(28) \times 8.5$	Screw $\frac{1}{8}(28) \times 8.5$	1 1	W502945H02
88	MG 30A0 153	案内テコツナギ	Feed connecting link	1 1	W483492H01
89	M9 1515 002	平ネジ $\frac{1}{8}(28) \times 10$	Screw $\frac{1}{8}(28) \times 10$	(2) (2)	B508963H 02
90	MG 42E0 152	案内テコ (組)	Feed regulator complete	1 1	A142D531G01
91	M9 1522 002	平ネジ $\frac{1}{8}(28) \times 16$	Screw $\frac{1}{8}(28) \times 16$	1 1	W461740H02
92	M9 0908 063	段付軸	Set pin	(1) (1)	A142D479H01
94	MF 60A1 640	ネジ 棒	Stitch length regulator screw	1 1	W484899H02
95	MG 42A0 572	押シバネ	Presser spring for stopper pin	1 1	W487125H01
96	M9 0420 060	ピン $4 \times 18$	Stopper pin for stitch length $4 \times 18$	1 1	W487124H01
97	MG 42A1 631	縫目加減ツマミ	Stitch length regulator dial	1 1	W344970H 02
98	M9 1209 002	平ネジ $\frac{3}{16}(28) \times 8$	Screw $\frac{3}{16}(28) \times 8$	1 1	B503887H01
99	M9 1516 002	平ネジ $\frac{1}{8}(28) \times 8.5$	Screw $\frac{1}{8}(28) \times 8.5$	2 2	W502945H02
100	M9 1207 003	丸平ネジ $\frac{3}{16}(28) \times 6.5$	Screw $\frac{3}{16}(28) \times 6.5$	1 1	B509288H01
101	MF 00A0 632	縫目加減レバー	Reverse sewing lever	1 1	A131C218H01
102	M9 5003 053	バネ座金	Spring washer	1 1	B503895H01
103	MF 60A0 633	縫目加減軸	Reverse stitch lever shaft	1 1	W462608H01
104	M9 1501 007	押先止メネジ $\frac{1}{8}(28) \times 14.5$	Screw $\frac{1}{8}(28) \times 14.5$	1 1	B509256H01
105	M9 1110 002	平ネジ $\frac{1}{8}(40) \times 8$	Screw $\frac{1}{8}(40) \times 8$	2 2	W500294H01
106	MG 30B0 708	バネ止メ板	Feed regulating spring holder	1 1	W462888H01
107	MF 60A0 572	ツル巻バネ	Spring	1 1	W445312H01
108	MG 41E1 635	縫目加減腕 (組)	Stitch length regulating bracket complete	1 1	W462614G04
109	MG 42A0 761	偏心軸	Eccentric pin	1 1	W487006H 02
216	MG 30A0 281	送り台	Feed bar	1 -	W484831H04
	MG 37A0 281	送り台	Feed bar	- 1	W483498G01
217	M9 0806 002	平ネジ $\frac{1}{8}(44) \times 6$	Screw $\frac{1}{8}(44) \times 6$	2 2	B508857H01
218	MF 10A0 104	送り台	Feed dog	1 1	W462604H01
219	MG 30A0 283	送り台支工軸	Feed bar holder stud	1 1	W483497H01
220	M9 0514 065	E形止メ輪	E-type stop ring	1 1	S922N210P50
221	M9 1110 002	平ネジ $\frac{1}{8}(40) \times 8$	Screw $\frac{1}{8}(40) \times 8$	2 2	W500294H01
222	MG 42A1 491	水平送り軸	Feed rock shaft	1 1	W488442H02
223	M9 1603 003	丸平ネジ $\frac{1}{4}(24) \times 16$	Screw $\frac{1}{4}(24) \times 16$	1 1	W501009H01
224	M9 0904 060	ピン	Pin for feed lifting rock shaft crank	2 2	W502476H02
225	MG 30B0 306	送り駆動腕	Feed lifting & rock shaft crank	1 1	W480463H01
226	MF 80A0 352	カラ	Collar	1 1	W482357H01
227	M9 1602 001	調節止メネジ $\frac{1}{4}(40) \times 4$	Set screw $\frac{1}{4}(40) \times 4$	2 2	W500036H01
228	MG 30A0 285	送り軸メタル	Feed rock shaft bushing	1 1	W483472H01
229	M9 1513 001	調節止メネジ $\frac{1}{8}(28) \times 10$	Set screw $\frac{1}{8}(28) \times 10$	1 1	B509060H01
230	M9 1516 002	平ネジ $\frac{1}{8}(28) \times 8.5$	Screw $\frac{1}{8}(28) \times 8.5$	2 2	W502945H02
231	M9 2403 034	センターネジ $\frac{3}{8}(28) \times 35$	Feed lifting rock shaft screw $\frac{3}{8}(28) \times 35$	2 2	W464015H01
232	M9 2402 045	ナット $\frac{3}{8}(28)$	Nut $\frac{3}{8}(28)$	2 2	B509118H01
233	MF 60A0 460	上下送り軸	Feed lifting rock shaft	1 1	W321790H01
234	MF 60E0 276	上下送り腕 (組)(左)	Feed lifting rock shaft crank complete (left)	1 1	W484829G03
235	M9 1203 002	平ネジ $\frac{3}{16}(28) \times 15$	Screw $\frac{3}{16}(28) \times 15$	2 2	B509178H01
236	MG 30A0 278	水平送り腕 (左)	Feed rock shaft crank (left)	1 1	W483499H01
237	M9 1502 050	特殊座金	Feed rock shaft bushing washer	1 1	W481674H01
238	M9 0315 065	C形止メ輪	C-type stop ring	1 1	S922N010P15
239	MG 30A1 285	送り軸メタル	Feed rock shaft bushing	1 1	W488434H01

5 上部送り機構  
UPPER FEED MECHANISM

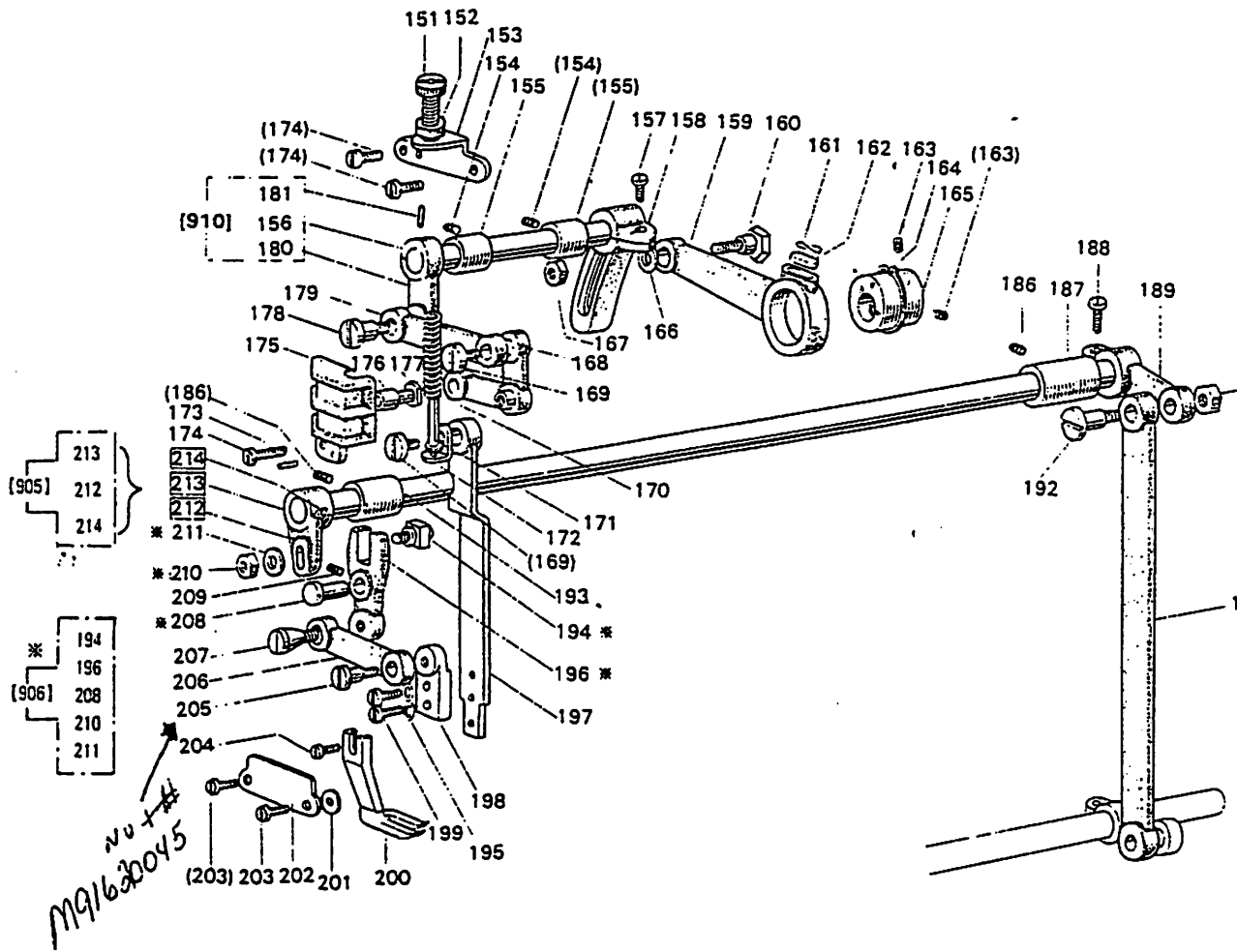

# UPPER FEED MECHANISM

Fig. No.	部品コード Parts No.	部品名	Description	使用個数 Amt. Req. DY-350 -12 -22	実材コード Ref. No.
151	M9 1801 035	調節ネジ	3/32(28)×35	1	W502411H01
152	M9 1802 045	ナット	3/32(28)	1	B508961H01
153	MG 3081 261	押エ調節台	Presser regulating bracket	1	W480473H01
154	M9 1108 001	頭ナシ止メネジ	1/4(40)×5.5	2	B503846H01
155	MG 30A0 833	送り軸メタル	(上部上下)	2	W483459H01
156	MG 30A0 460	上部上下軸	Feed lifting rock shaft	1	W483458H02
157	M9 1603 003	丸平ネジ	1/4(24)×16	1	W501009H01
158	MG 30A0 463	上部上下送り腕	(右)	1	W483457H02
159	MG 3080 384	クランクロッド	(連絡棒)	1	W480485H01
160	M9 1551 015	特殊ボルト	M6×24	1	W480471H02
161	MF 60A0 700	バネ	Spring for felt stopper	1	W500836H01
162	MG 3080 740	フェルト	Felt for feed connecting crank rod	1	W464014H01
163	M9 1606 001	頭ナシ止メネジ	1/4(40)×7	2	B504016H01
164	M9 0325 065	C形止メ輪	(偏心輪)	1	S922N010P25
165	MG 30A0 760	偏心心輪	Feed lifting eccentric	1	W483455H01
166	M9 0607 050	ミガキ座金	6	1	S913N040P06
167	M9 1572 045	Uナット	M6×0.75	1	S910N652P06
168	MG 1080 763	ベルクランク	Bell crank	1	W461042H01
169	M9 1210 002	平ネジ	3/16(28)×10	2	W501247H01
170	MG 1080 259	押エバネ	(ツル巻バネ)	1	W502462H01
171	MG 3080 732	ピン案内金	(組)	1	W464020G01
172	MG 3080 226	押エ板支エ	(受金)	1	W461057H01
173	M9 0307 064	スプリングピン	Spring pin	2	S921N333P08
174	M9 1110 002	平ネジ	1/4(40)×8	3	W500294H01
175	MG 3081 765	ベルクランクガイド	Bell crank guide bracket	1	W480467H01
176	MG 1080 411	コロ	Bell crank guide bracket block	1	W501534H01
177	M9 0507 063	コロ	(支工輪)	1	W502457H01
178	M9 1681 015	段付平ネジ	1/4(40)×12	1	W480472H01
179	MG 1080 910	リンク	(連絡棒)	1	W457552H01
180	MG 30A0 462	上部上下送り腕	(左)	1	W488479H01
181	M9 1506 002	テーパピン	Taper pin	1	W488368H01
910	MG 30E0 460	上部上下軸	(組)	1	W488478G01
186	M9 1108 001	頭ナシ止メネジ	1/4(40)×5.5	2	B503846H01
187	MG 3080 287	上部水平送り軸メタル	(右)	1	W466249H01
188	M9 1603 003	丸平ネジ	1/4(24)×16	1	W501009H01
189	MG 30E0 465	上部水平送り腕	(右)	1	W462666H01
190	M9 1802 045	ナット	3/32(28)	1	B508961H01
191	MG 3080 954	連結リンク	Feed drive connecting link	1	W324564H01
192	M9 1803 015	段付平ネジ	3/32(28)×26.1	1	W454870H01
193	MG 3080 285	上部水平送り軸メタル	(左)	1	W457554H01
194	MG 50E0 410	コロ	Feed connecting slick block complete	1	W488427G02
195	M9 0307 053	バネ座金	3.5	2	S913N210P03
196	MG 50A0 950	交換レバー	Feed connecting lever	1	W483462H02
197	MG 3080 295	送り足支エ	Walking foot guide link	1	W461085H01
198	MG 3082 273	送り足腕	(取付金)	1	W480470H02
199	M9 0903 002	平ネジ	3/16(40)×6.5	2	B509065H01
200	MG 1080 294	送り足	Walking foot	1	W321338H01
201	M9 0453 050	座金	Washer	2	W480469H02
202	MG 30A0 296	送り足支エ案内	Walking foot guide bracket	1	W483464H01
203	M9 1112 002	平ネジ	1/4(40)×12	2	W501889H01
204	M9 0922 002	平ネジ	3/8(40)×8	1	W464016H01
205	M9 1681 015	段付平ネジ	1/4(40)×12	1	W480472H01
206	MG 30A0 910	リンク	(連絡棒)	1	W483495H01
207	M9 1601 036	テーパ頭ネジ	1/4(40)×26	1	W487003H01
208	MG 30A0 530	段付腕	Hinged pin	1	W483463H02
209	M9 1506 001	頭ナシ止メネジ	3/16(28)×6	1	B509087H01
210	M9 1602 045	ナット	1/4(24)	1	W501058H02
211	M9 0601 050	座金	Washer	1	S913N040P06
212	MG 3080 464	上部水平送り腕	(左)	1	W464053H01
213	MG 3080 467	上部水平送り軸	Feed driving shaft (upper)	1	W461080H01
214	M9 0401 061	テーパピン	Taper pin	1	W501209H01
905	MG 42E0 467	上部水平送り軸	(組)	1	W346058G02
906	MG 42E0 950	交換レバー	(組)	1	A142D532G01

### ⑥ 押工機構

## PRESSER FOOT MECHANISM

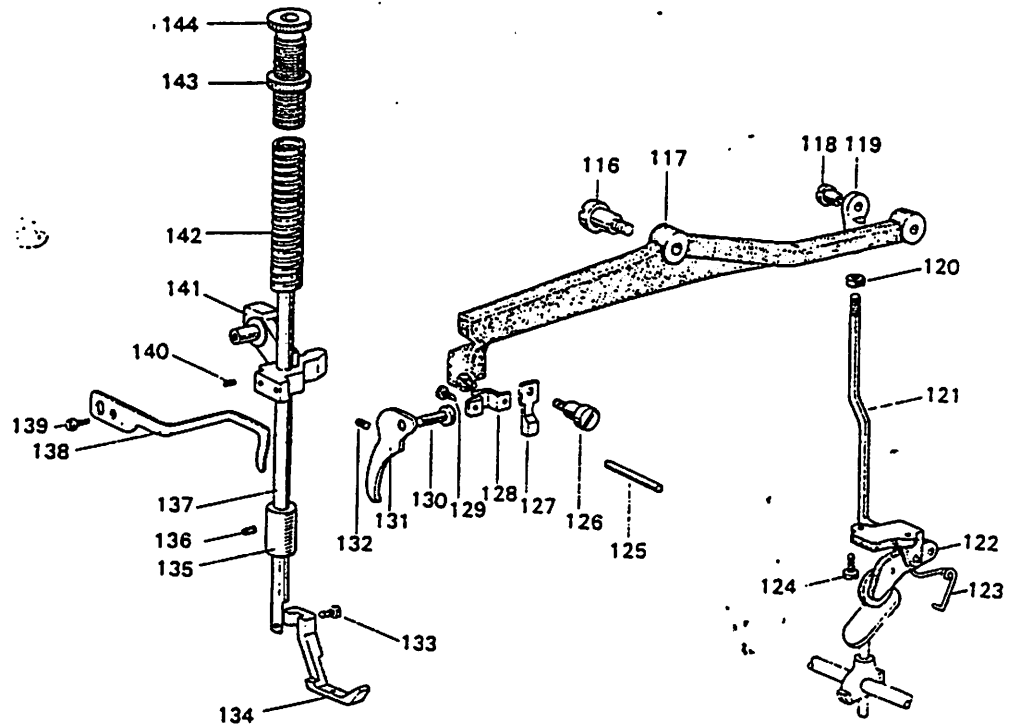

### ⑦ 給油機構

## OIL LUBRICATION MECHANISM

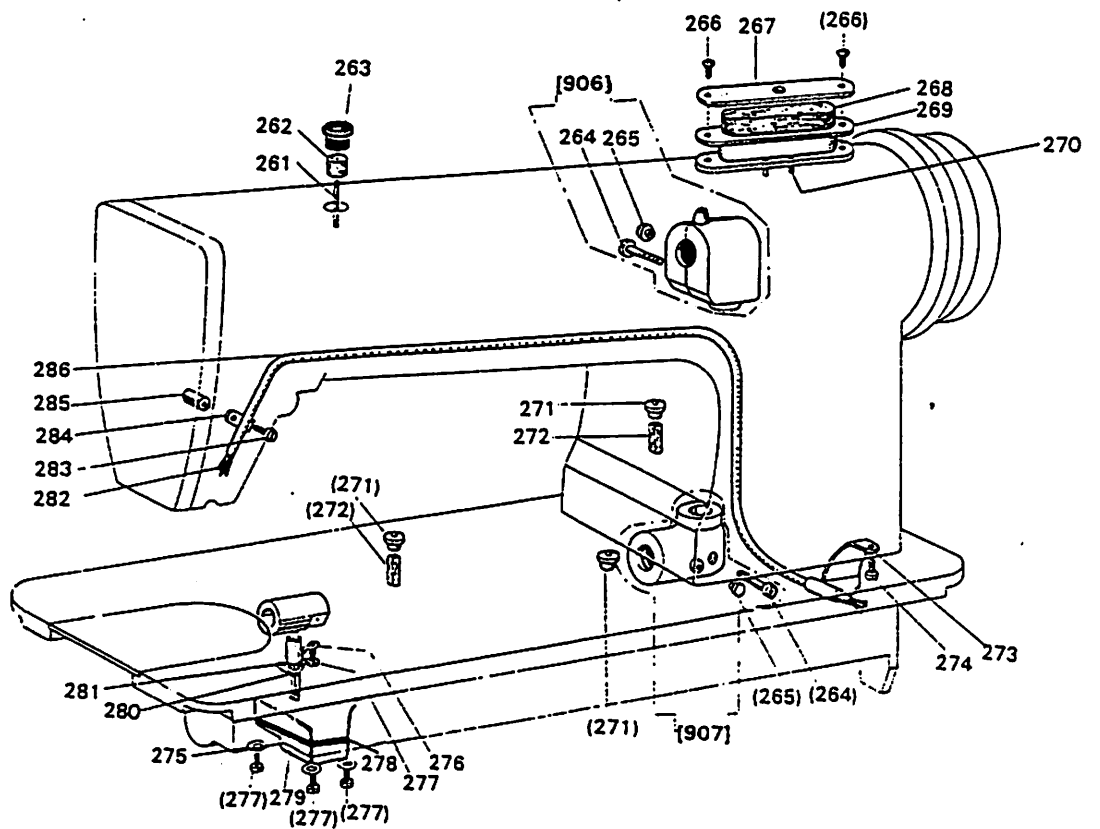

# PRESSER FOOT MECHANISM

Fig. No.	部品コード Parts No.	部品名	Description	使用個数		資材コード Ref. No.	
				Amt. Req.	DY-350 -12 -22		
116	M9 2001 016	段付丸平ネジ	$\frac{3}{8}$ (24)×30	Hinged screw $\frac{3}{8}$ (24) × 30	1	1	B503843H01
117	MG 30A0 725	膝上ゲレバー	(上)	Lifting lever (upper)	1	1	W344931H01
118	M9 1505 016	段付丸平ネジ	$\frac{3}{8}$ (28)×10	Hinged screw $\frac{3}{8}$ (28) × 10	1	1	B509176H01
119	MG 40A0 591	テコ撥手		Knee lifter rock shaft arm	1	1	W462748H02
120	M9 1251 045	ナット	$\frac{3}{8}$ (32)	Nut $\frac{3}{8}$ (32)	1	1	B509177H01
121	MG 30B0 593	テコ引棒		Lifting lever connecting rod	1	1	W461082H01
122	MG 30E1 594	テコ引仕掛	(組)	Knee lifter bell crank complete	1	1	W482314G02
123	MG 30B1 729	ヒネリバネ		Knee lifter ball crank spring	1	1	W464022H02
124	M9 1104 003	丸平ネジ	$\frac{1}{2}$ (40)×12	Screw $\frac{1}{2}$ (40) × 12	2	2	B509264H01
125	M9 0414 060	糸ユルメピン	$\phi 4 \times 44$	Upper thread releasing pin $\phi 4 \times 44$	1	1	W502957H03
126	M9 1223 015	段付平ネジ	$\frac{3}{8}$ (28)×6.2	Hinged screw $\frac{3}{8}$ (28) × 6.2	1	1	W487004H01
127	MG 30B1 222	糸ユルメ	(糸ユルメカム)	Upper thread releasing cam	1	1	W483465H02
128	MG 30A0 154	案内金		Guide plate	1	1	W483466H01
129	M9 1109 002	平ネジ	$\frac{1}{2}$ (40)×7	Screw $\frac{1}{2}$ (40) × 7	2	2	W500511H01
130	M9 0704 063	押エ上ゲピン		Presser foot lifting pin	1	1	B503977H01
131	MF 60A0 252	押エ上ゲ		Presser foot lifter	1	1	W443698H01
132	M9 1109 001	頭ナシ止メネジ	$\frac{1}{2}$ (40)×8.5	Set screw $\frac{1}{2}$ (40) × 8.5	1	1	B509339H01
133	M9 0922 002	平ネジ	$\frac{3}{8}$ (40)×8	Screw $\frac{3}{8}$ (40) × 8	1	1	W464016H01
134	MG 10B0 256	押エ足		Presser foot (inside)	1	1	W464028H01
135	MG 30B0 267	押エ棒メタル	(下)	Presser bar bushing (under)	1	1	W462887H01
136	M9 1102 001	頭ナシ止メネジ	$\frac{1}{2}$ (40)×2.7	Set Screw $\frac{1}{2}$ (40) × 2.7	2	2	W500489H01
137	MF 60A0 262	押エ棒		Presser bar	1	1	W444011H01
138	MN 30A0 216	糸案内		Thread guide	1	1	W502468H01
139	M9 1109 002	平ネジ	$\frac{1}{2}$ (40)×7	Screw $\frac{1}{2}$ (40) × 7	1	1	W500511H01
140	M9 1506 001	頭ナシ止メネジ	$\frac{1}{2}$ (28)×6	Set screw $\frac{1}{2}$ (28) × 6	1	1	B509087H01
141	MG 10B0 265	押エ棒ダネ		Presser bar holder	1	1	W463535H02
142	MV 01A0 259	押エバネ		Presser bar spring	1	1	W461782H01
143	M9 3201 045	特殊ナット	$\frac{1}{2}$ (28)	Special nut $\frac{1}{2}$ (28)	1	1	W471438H01
144	M9 3201 035	押エ調節ネジ	$\frac{1}{2}$ (28)×43	Thumb screw $\frac{1}{2}$ (28) × 43	1	1	B409037H02

## 7 給油機構

# OIL LUBRICATION MECHANISM

Fig. No.	部品コード Parts No.	部品名	Description	使用個数		資材コード Ref. No.	
				Amt. Req.	DY-350 -12 -22		
261	MF 10E2 148	油 紐	$\phi 2.5 \times 35$	Oil wick $\phi 2.5 \times 35$	1	1	W488988H01
262	MF 60A5 740	フェルト		Felt for oiler	1	1	W500906H01
263	MG 41B0 742	油 蓋		Cap for oiler	1	1	W471448H01
264	M9 0510 037	Pナベネジ	M5×12	Screw M5 × 12	2	2	S900N015P12
265	M9 0570 080	ゴム栓		Rubber plug	2	2	W502078H01
906	MF 60E1 711	歯車箱上	(組)	Arm shaft bevel gear box complete	1	1	W482329G02
266	M9 1109 002	平ネジ	$\frac{1}{2}$ (40)×7	Screw $\frac{1}{2}$ (40) × 7	2	2	W500511H01
267	MF 60A0 134	油 蓋	(右)(油タンク)	Oil reservoir cover (right)	1	1	W445619H01
268	MF 60A4 740	フェルト		Felt for oil reservoir	1	1	W500905H01
269	MG 30A0 139	油タンク	(右)	Oil reservoir (right)	1	1	W447200H03
270	MF 10E2 148	油 紐	$\phi 2.5 \times 150$	Oil wick $\phi 2.5 \times 150$	1	1	W488988H04
271	MN 10A4 742	蓋	(オイルカップ)	Cap for oiler	3	3	W462905H01
272	MG 30A0 740	フェルト	4×5-35	Felt for oiler 4 × 5 — 35	2	2	W462954H03
273	MF 65B0 690	管 押エ		Oil pipe holder	1	1	W501200H02
274	M9 0920 002	平ネジ	$\frac{3}{8}$ (40)×6.5	Screw $\frac{3}{8}$ (40) × 6.5	1	1	W501523H01
907	MG 41E0 712	歯車箱下	(組)	Hook shaft bevel gear box complete	1	1	W481406G01
275	M9 0406 050	座 金	4.5	Washer 4.5	5	5	W470913H01
276	MG 42A0 689	センサイクパネ	(パイプホルダー)	Pipe holder	1	1	W487120H01
	MG 43A0 689	センサイクパネ	(パイプホルダー)	Pipe holder	—	1	W487120H02
277	M9 1101 004	ブラマイネジ	$\frac{1}{2}$ (40)×8	Screw $\frac{1}{2}$ (40) × 8	5	5	W466810H01
278	MG 42A1 691	ガスケット		Gasket for oil reservoir	1	1	A142D547H01
279	MG 42A0 139	油 蓋		Oil reservoir cover	1	1	A142D581H01
280	MS 07A0 740	フェルト		Felt	1	1	W462954H02
281	MG 42A1 731	ビニールパイプ	6×8-15	Oil pipe 6 × 8 — 15	1	1	W462995H03
282	MG 42B0 400	毛糸		Wool yarn	1	1	W464010H02
283	M9 1111 003	丸平ネジ	$\frac{1}{2}$ (40)×10	Screw $\frac{1}{2}$ (40) × 10	1	1	W500164H01
284	MF 10A0 689	パイプホルダー		Pipe holder	1	1	W444230H01
285	M9 1103 045	ナット	$\frac{1}{2}$ (40)	Nut $\frac{1}{2}$ (40)	1	1	W501528H01
286	MG 42A3 731	パイプ	$\phi 3 \times \phi 4 \times 520$	Oil pipe $\phi 3 \times \phi 4 \times 520$	1	1	W484810H04

# 8 付属品関係 ACCESSORIES

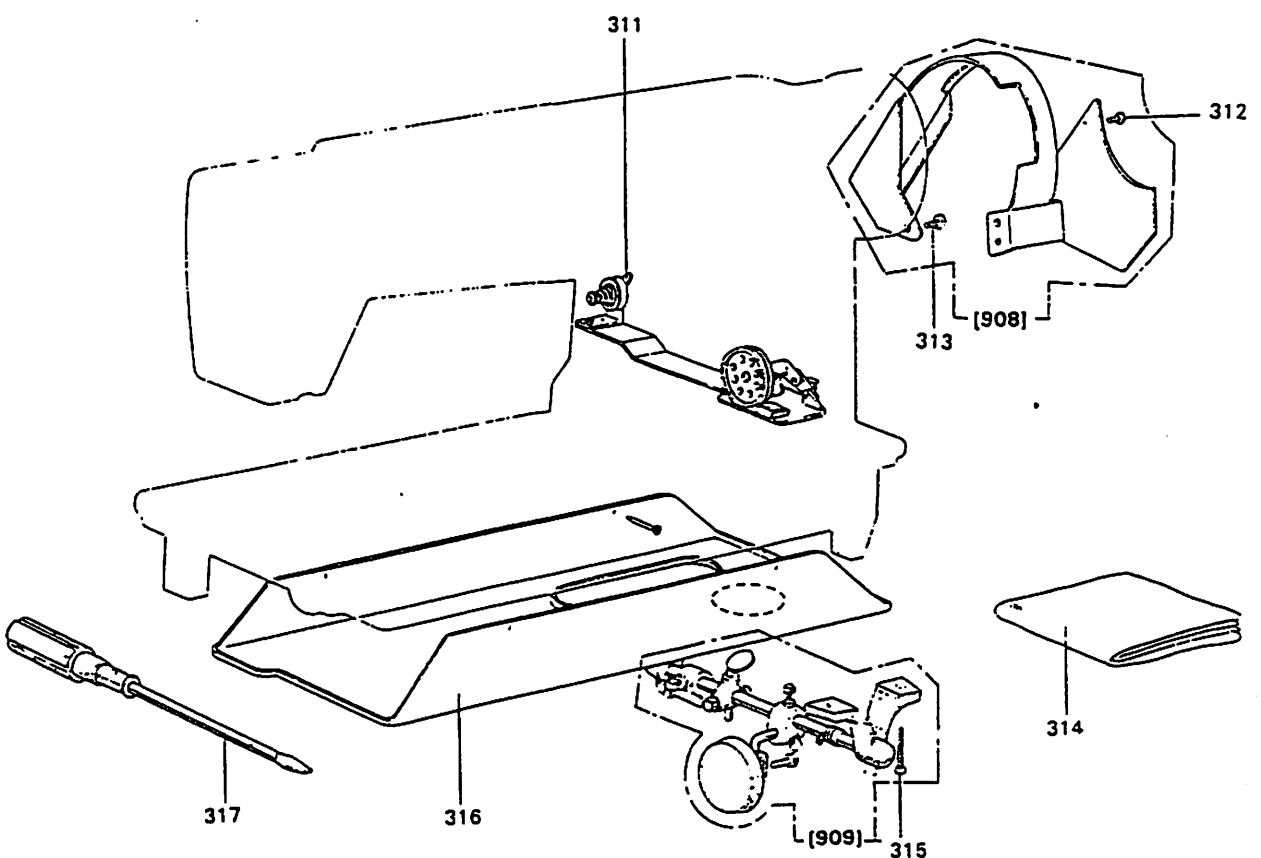
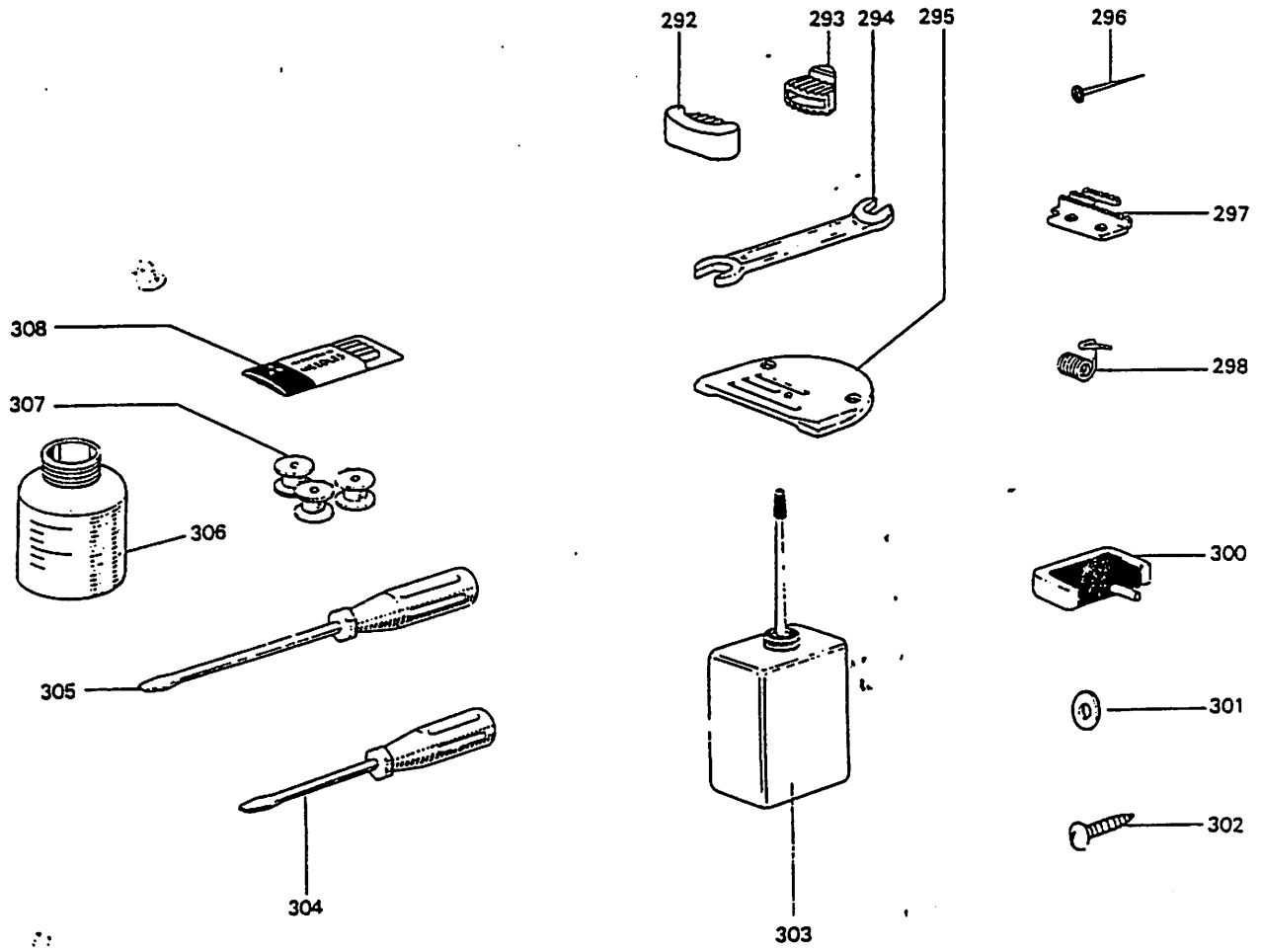

# ACCESSORIES

Fig. No.	部品コード Parts No.	部品名	Description	使用個数		資材コード Ref. No.
				Amt. Req.	DY-350 -12 -22	
292	MG 42A0 419	防振ゴム (大)	Vibration preventing rubber	2	2	W481654H02
293	MG 42A1 419	防振ゴム (小)	Vibration preventing rubber	2	2	W481655H02
294	MM 10A1 479	スパンナ	Spanner	1	1	B422776H01
295	MF 26B0 101	(輸出用)	Needle plate (B-2.6) (7 mm)	1	1	W322721H01
296		釘 N25	Nail N25	10	10	S928N900P25
297	MF 10A0 104	(輸出用)	Feed dog	1	1	W462604H01
298	MF 12B0 187	糸取リバネ	Thread take-up spring	1	1	W486372H02
300	MF 00E0 418	ゴムヒンジ (組)	Table hinge complete	2	2	A142D296G01
301	M9 0601 050	ミガキ座金 6	Washer 6	2	2	S913N040P06
302	M9 0405 041	丸木ネジ 4.5×20	Screw 4.5 × 20	2	2	S908N159P01
303	MF 60A0 137	油差シ	Oil with oiler	1	1	P831001X02
304	MB 02A1 608	ドライバー (小)	Screw driver (Small)	1	1	P842002X01
305	MB 02A0 608	ドライバー (中)	Screw driver (Middle)	1	1	P842003X01
306	MN 10A0 130	油ビン	Oil pot	1	1	W346040H01
307	MF 10A0 123	ボビン	Bobbin	3	—	S976019X01
	MF 25B0 123	ボビン	Bobbin	—	3	S976021X01
308	MF 83A0 128	針 DB × 1 #22	Needle DB × 1 #22	4	—	S970002H03
	MG 37A0 128	針 DP × 17 #22	Needle DP × 17 #22	—	4	S970005H07
311	MF 20E0 190	糸巻仕掛	Bobbin winder complete	1	—	P992002X01
	MF 67E0 190	糸巻仕掛	Bobbin winder complete	—	1	P992004X01
312	M9 1106 004	ブラマイネジ 1/4(40)×8	Screw 1/4(40) × 8	3	3	W466810H02
908	MG 42E0 776	ベルトカバー (組)(国内用) B E-2		1	—	A131C264G01
	MG 43E0 776	ベルトカバー (組)(国内用) B E-4		—	1	A131C264G07
313	M9 1508 004	プライマネジ 1/4(28)×8	Screw 1/4(28) × 8	3	3	W467868H04
314	MF 60A0 734	ビニールカバー	Vinyl cover	1	1	W220627H02
315	M9 0404 040	木ネジ (輸出用)	Screw 4.5 × 25	4	4	S908N079P01
909	MF 60E1 727	ヒザアゲ仕掛 (輸出用)	Knee lifter complete	1	1	W219640G02
316	MG 42E0 131	油受け (組)	Oil pan	1	1	W344933G02
317	MF 60A0 608	ドライバー (大)	Screw drive (large)	1	1	W319408H01